



This manual is for reference and historical purposes, all rights reserved.

This page is copyright© by M. Butkus, NJ.

This page may not be sold or distributed without the expressed permission of the producer

I have no connection with any camera company

On-line camera manual library

This is the full text and images from the manual. This may take 3 full minutes for the PDF file to download.

If you find this manual useful, how about a donation of \$3 to: M. Butkus, 29 Lake Ave., High Bridge, NJ 08829-1701 and send your e-mail address so I can thank you. Most other places would charge you \$7.50 for a electronic copy or \$18.00 for a hard to read Xerox copy.

This will allow me to continue to buy new manuals and pay their shipping costs.

It'll make you feel better, won't it?

**If you use Pay Pal or wish to use your credit card,
click on the secure site on my main page.**

H A S S E L B L A D

Instruction Manual
Gebrauchsanweisung
Mode d'emploi
Manual de instrucciones
Bruksanvisning

PME 51

42296

PM5

42308

(GB)

(D)

(F)

(E)

(S)

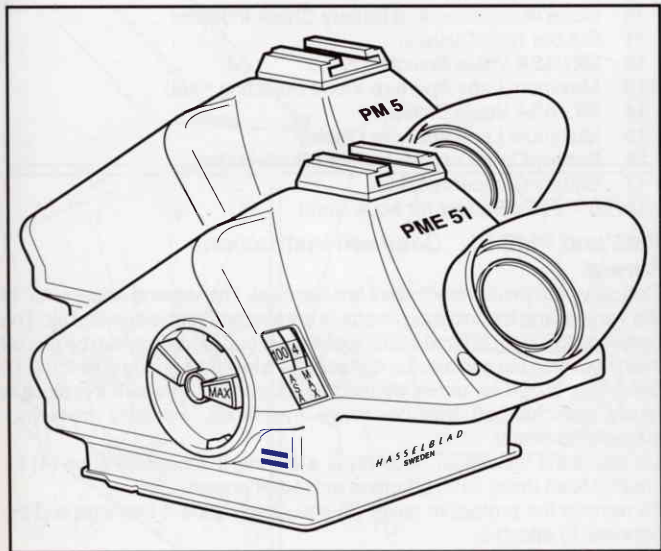



1

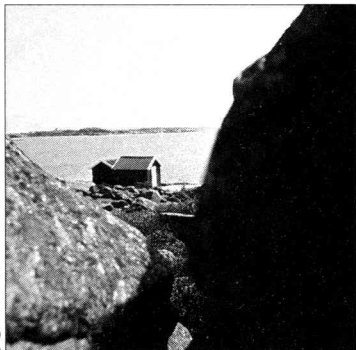

2



3



4



5

Exposure samples;
see page 10.
Belichtungsbeispiele;
siehe Seite 18.
Exemples d'exposition;
voir page 27.
Muestras de exposición;
ver pág. 35.
Exponeringsexempel;
se sidan 43.

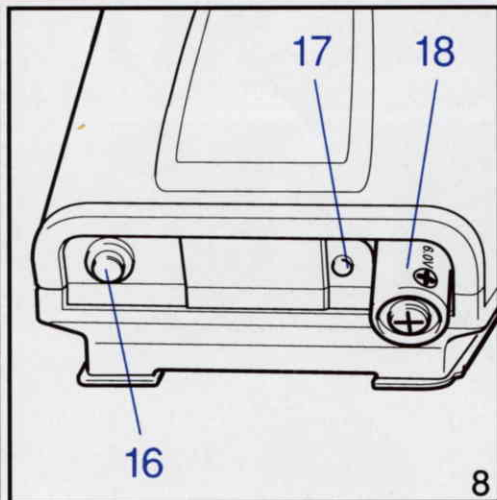
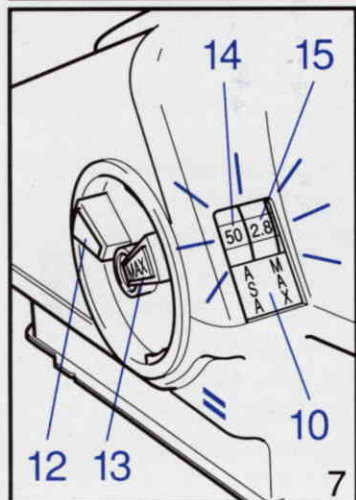
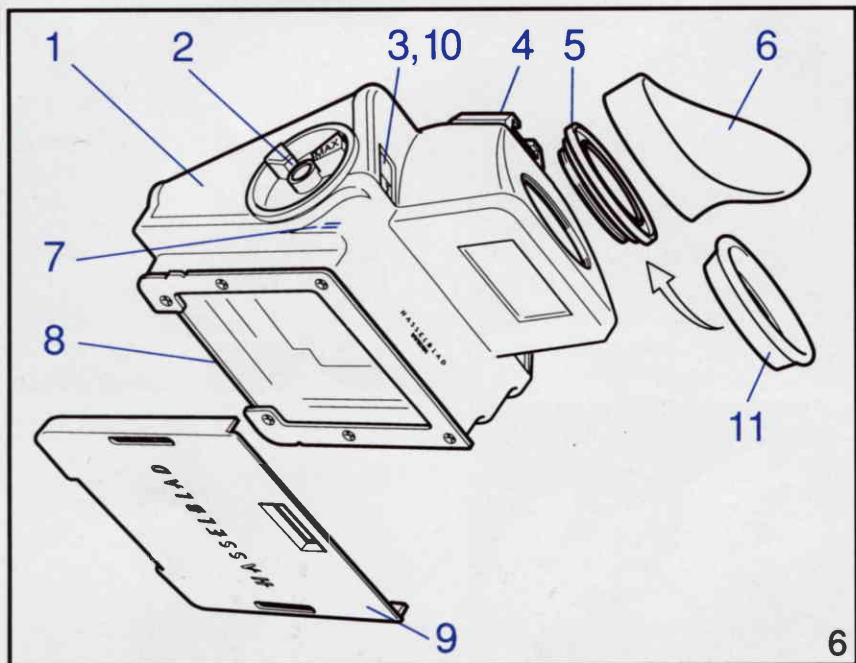

Hasselblad Prism Viewfinder PM5 and Meter Prism Viewfinder PME 51

Parts and Components

Items marked * are applicable on both PM5 and PME51

- * 1 Viewfinder Body
- 2 Meter Control Knobs
- 3 Setting Scale and Battery Check Window
- * 4 Top Accessory Shoe
- * 5 Interchangeable Eyepiece
- * 6 Rubber Eye-cup
- * 7 TCC System Mark
- * 8 Mounting plate with TCC Display Recess
- * 9 Protective Cover
- 10 Scale Illumination and Battery Check Indicator
- * 11 Rubber Ring Cushion
- 12 ISO/ASA Value Selecting Knob
- 13 Maximum Lens Aperture Value Selecting Knob
- 14 ISO/ASA Value Display
- 15 Maximum Lens Aperture Display
- 16 Battery Check and Meter Start Push-button
- 17 Battery Compartment Lid
- 18 6 V PX28 Battery (or equivalent)

PM5 and PME 51 Common instructions

General

Optically both prism viewfinders are identical. The viewing angle is 45° to the vertical and the focusing image is unreversed and magnified 3x. The eyepiece (5, fig. 6) is fitted with a rubber eye-cup (6), which can be placed in any position but can also be replaced by a low rubber ring cushion (11), especially suited for users wearing eyeglasses. The entire eyepiece is easily interchanged with corrective eyepieces, available from your Hasselblad dealer.

On top of the viewfinder body (1) is a standard accessory shoe (4) for smaller flash units, flash adapters and other accessories.

To remove the protective cover (9) you simply slide it forwards and the opposite to attach it.

Attaching the viewfinder to the camera

For camera operation please refer to the camera instruction manual. Insert the viewfinder in the viewfinder mount on top of the camera body. Push the viewfinder forwards until it reaches a positive stop. When used on the 205TCC it activates a switch in the end position, causing the viewfinder display to adapt to the unreversed focusing image. The viewfinder is kept in place when a magazine or the back protective cover is attached.

Corrective eyepieces

You can compensate for your individual eyesight by substituting the entire attached standard eyepiece for one with correction power. Unscrew the standard eyepiece by rotating it counter-clockwise and screw in the corrective eyepiece instead. Keeping the rubber eye-cup or cushion ring on gives a much better grip on the eyepiece when you screw it in or out. Corrective eyepieces, which also fit all PM and PME type viewfinders, are available in power steps of one diopter from - 4 through + 3 diopters. Consult your optician for recommendation on your individual correction power!

Care and maintenance

Treat the PM5 and PME51 Prism Viewfinders with the same care as any other optical instrument. Keep glass surfaces clean using a lens brush. Keep the protective cover on whenever the viewfinder is not attached to the camera.

PME 51 only Detail instructions

The PME51 features center-weighted integral metering, using a silicon cell with fast response. It is the perfect complement to the spotmeter in the Hasselblad 205TCC for overall metering where the spotmeter provides accurate metering of defined subject areas, but it works just as well on all Hasselblad SLR models. The metered values are indicated by a row of EV numbers, ranging from 2 to 19, underneath the focusing screen, illuminated by red light diodes. The film speed range covers ISO/ASA 25 - 6400 (DIN 15 - 39).

The operating knobs and buttons are countersunk and scales and indicators are behind windows to protect from physical damage and contamination.

The EV indicated in the viewfinder has to be transferred manually to the lens' EV scale, giving you the opportunity to make whatever correction to the reading you consider necessary, as integral metering can be affected by dominating bright or dark areas in the subject.

Battery

The battery is a 6 V, type PX28 (U1, 4G-13, 537 etc). An alkaline or silver oxide battery will be adequate for normal use, but lithium types are recommended for cold conditions.

Battery installation

The battery compartment lid (17, fig. 8) is spring loaded. Slide it to the left and hold it there while inserting the battery with the positive (+) terminal facing outward (18). Release the lid and push the battery into the compartment until the lid slides back over the battery. Check that the lid is completely closed.

Battery check

After inserting the battery or whenever you start using the PME 51, you should check the battery condition. Depress the battery check button (16, fig. 8) while observing the battery check indicator window (10, fig. 7). As long as the button is kept depressed a green light appears in the window (3, fig. 6) when the battery is satisfactory. Do not keep the button depressed longer than required to check the light, since the test function consumes battery energy.

Always remove the battery when the PME 51 is stored or not used for long periods!

Even if the battery check is satisfactory, alkaline batteries should not be kept in the PME 51 for more than a year to avoid damage due to battery leakage.

NOTE: Depressing the button (16) also starts the metering system (see below). Each time you start the system the green light appears as long as the battery is in good order.

The EV display

The EV for the metered subject area as seen on the focusing screen is displayed underneath the lower edge of the focusing image. The metering range is EV 2 through EV 19. The EV appears for approx. 10s, illuminated in red, after which the meter shuts itself off. It can then be restarted for another 10 s by depressing the button (16) again.

NOTE: If no EV appears, although the battery is in good order, the ISO/ASA and MAX aperture settings combined with the light conditions may have resulted in an EV outside the meter's range.

How to use the PME 51

Three different settings should be made or checked before you start using the meter:

1. The lens must not be stopped down. Readings should always be taken with the lens wide open.
2. Set the maximum aperture of the lens (the lens' speed) in the clear part of the window over the mark MAX (15, fig. 7) using the selector knob, also marked MAX (13). For legibility reasons the intermediate half f-stops have been omitted from the scale.

The complete scale reads:

Half f-stops:	2.4	3.4	4.8	6.8	
Full f-stops:	2	2.8	4	5.6	8

3. Set the ISO/ASA film speed in the clear part of the of the window over the mark ASA (14, fig. 7) using the unmarked selector knob (12). For legibility reasons only the most common ISO/ASA values have been indicated.

The complete scale, including the DIN values, reads:

ISO/ASA	25	50	100	200	400	800	1600	3200	6400
DIN	15	18	21	24	27	30	33	36	39

The meter viewfinder is now ready for use.

Taking readings

Keep in mind that the EV produced by an integral reflexion exposure meter is an average that corresponds to an overall 18% grey surface!

Aim the camera at the subject and start the meter by a short push on the meter start button (16, fig. 8). Do not keep it depressed - half a second is sufficient. The exposure value is displayed on the EV scale underneath the viewfinder image until the meter automatically turns itself off after approx. 10 s. Pushing the button again revives the meter for another 10 s. Normally a single EV is illuminated, but stray light may also faintly illuminate the next higher and lower EV. However, if two adjacent EV appear equally bright,

the correct EV is the half step in between. Transfer the reading to the orange EV scale on the right hand side of the lens. The scale has click-stops for each full EV and also for each intermediate half EV setting.

The metering is made in real time. The displayed EV cannot be locked or stored. When you move the camera about in the subject, the displayed EV will keep changing as the brightness of the subject changes.

NOTE: The eye must be kept close to the rubber eye-cup (6, fig. 6) during the metering. Stray light entering the viewfinder through the eye-piece can lead to an erroneous reading.

Changing lens and film

When changing the lens, do not forget to set new maximum aperture (lens speed) with the MAX selector knob (13, fig. 7). The same applies when you change to a film with a different film speed: Remember to set the new film speed with the unmarked selector knob (12, fig. 7).

Changing focusing screen

The exposure meter in your PME 51 Viewfinder is adjusted to the very bright Acute-Matte* focusing screens. If you change to any other of the Hasselblad focusing screens or use the PME 51 on earlier Hasselblad camera models you have to compensate for the lower brightness of these screens. Use one of the three equally effective ways described below to carry out the compensation:

1. **Increase** the ISO/ASA setting to twice the film speed as marked on the film package (e.g. to 200 for a ISO/ASA 100 film)
or
2. **Reduce** the MAX lens aperture setting one full stop (e.g. to f/4 for an f/2.8 lens).
or
3. **Increase** the EV reading one full step when you transfer it to the EV scale on the lens (e.g. to EV13 when the meter displays EV12)

Exposure Compensation

A. Intentional over- or under-exposure

If you have found that you prefer an exposure deviating from the "normal", the easiest way to obtain it is to set a film speed, that is different from the nominal speed marked on the film box. Use the film speed selector knob

(12, fig. 7) to set the required ISO/ASA setting as described above. When you set half the nominal film speed, the displayed EV corresponds to an overexposure of one full f/stop.

When you set double the nominal film speed, the displayed EV corresponds to an underexposure of one full f/stop.

The intermediate settings on the ISO/ASA scale correspond to 1/3 EV step each.

B. Different filters and lenses

The PME51 meter obtains its information from the light passing through the lens and falling on the focusing screen. Thus, any filter attached to the lens will automatically be compensated for. When you are using a Hasselblad filter the deviation from the true EV by the EV displayed in the viewfinder will never exceed 1/3 EV but varies from filter to filter. Individual variation between lenses may amount to $\pm 1/2$ EV. Since these variations in filters and lenses could cancel out or reinforce each other, you are recommended to make test exposures to determine the need for calibration of your own equipment.

C. Focusing screens

The basic compensation for other screens than the Acute-Matte* screens is described above (Changing focusing screen). However, there are differences between the other Hasselblad screens too. To find out the degree of compensation your equipment requires you should make test metering and exposures. When you have established the degree of compensation it can be carried out as described above.

NOTE: The Plain Glass Screen (Cat. No. 42200) is not suitable for metering with the PME 51.

D. Focusing screen masks

The focusing screen masks for the 6x4.5 cm and 4x4 cm formats also affect the readings and should be compensated for. Test exposures with your own equipment are recommended. Observe that when using these formats bright or dark areas outside the format may affect the meter's readings.

NOTE: The solid black masks should not be used.

Additional care and maintenance, PME 51

Remove the battery regularly to clean it for better contact, and check for battery leakage. If there is the slightest sign of leakage, discard the battery,

clean the battery compartment carefully using a suitable contact cleaning agent, and install a fresh battery. **DO NOT use water for the cleaning!** Also remove the battery when the viewfinder is stored or unused for extended periods.

Hints on metering

(See pictures 1 - 5 on the fold-out page)

Even illumination (Picture 1)

When the illumination is acceptably even over the entire subject, aim the camera at the subject and read the displayed EV.

Subject with high contrast (Picture 2)

In the center-weighted meter the photocell reads the light from the entire focusing screen, but it is more influenced by the center of the screen than by the sides. The reading is largely an average for the intensity of the light reaching the focusing screen. When the subject has large areas with widely different brightness you have to decide whether to expose for the bright or for the dark areas. The camera then must be aimed for the chosen area. It may even be necessary to move in close to this area to avoid influence from other areas or to find a substitute area with a similar brightness for the meter reading.

Bright subject - dark background (Picture 3)

To get the two persons in the foreground properly exposed, a close-up reading must be made of their or a similar clothing with the same illumination. Otherwise the dark background would cause the meter to display too low a reading.

Dark subject - bright background (Picture 4)

Also in this case you must avoid the influence from the background. If you cannot move in on the main subject you could increase the exposure by reducing the EV one or two steps (e.g. from EV14 to EV12).

Backlit scenes (Picture 5)

Again take the reading as close to the subject as possible. Try to shade off direct light from entering the lens. Avoid influence from the open sky by using a suitable sunshade. Reducing the obtained EV reading by one or two steps may be necessary for a good rendition of shadow details.

Sea and snow

A beach with bright sand, a sea-scape with reflections in the water or a snow-covered landscape reflects large amounts of light and may give unwanted high EV readings to overall metering. Take the readings as close to the main subject as possible or try to find a representative surface with a brightness, similar to the subject.

Close-up photography

Since the Hasselblad PME 51 meter prism viewfinder reads the light after it has passed through the lens, it automatically compensates for the increased exposure when you are using extension tubes or bellows in close-up photography.

PME 51 on the 205TCC

Since the PME 51 is not connected to the camera, it can be used on the 205TCC as an overall exposure meter to check the general light level of the subject. You can easily convert the EV reading to exposure data by entering it on the EV scale on the right hand side of the lens and read the shutter speed off the shutter speed scale opposite the selected aperture value.

If you wish to use the EV reading from the PME 51 you should set the 205TCC at Manual (**M**) mode, select aperture or shutter speed, and enter the EV reading from the PME 51 on the EV scale. You can then use the spotmeter in the camera to monitor the EV difference between that setting and any part of the subject area.

Tolerances

Exposure deviations may depend on a number of factors. The tolerances of the individual parts in a photographic setup, such as film, lens, shutter and diaphragm may cancel out or enhance each other. The best way for you to avoid unpleasant surprises is to evaluate the PME 51 together with the rest of your equipment and keep track of the special adjustments that give you the best result.